

Effect of Reflow Profile on SnPb and SnAgCu Solder Joint Shear Force

Jianbiao Pan¹, Brian J. Toleno², Tzu-Chien Chou¹, Wesley J. Dee¹,
¹California Polytechnic State University, San Luis Obispo, CA 93407
²Henkel Technologies, 15350 Barranca Parkway, Irvine, CA 92618

Abstract

Reflow profile has significant impact on solder joint performance because it influences wetting and microstructure of the solder joint. The degree of wetting, the microstructure (in particular the intermetallic layer), and the inherent strength of the solder all factor into the reliability of the solder joint. This paper presents experimental results on the effect of reflow profile on both 63%Sn 37%Pb (SnPb) and 96.5%Sn 3.0%Ag 0.5%Cu (SAC 305) solder joint shear force. Specifically, the effect of the reflow peak temperature and time above solder liquidus temperature are studied. Nine reflow profiles for SAC 305 and nine reflow profiles for SnPb have been developed with three levels of peak temperature (230°C, 240°C, and 250°C for SAC 305; and 195°C, 205°C, and 215°C for SnPb) and three levels of time above solder liquidus temperature (30 sec., 60 sec., and 90 sec.). The shear force data of four different sizes of chip resistors (1206, 0805, 0603, and 0402) are compared across the different profiles. The shear force of the resistors is measured at time 0 (right after assembly). The fracture surfaces have been studied using a scanning electron microscopy (SEM) with energy dispersive spectroscopy (EDS).

Introduction

The increasing awareness of health risk associated with lead (Pb) containing solder alloys has pushed the electronics industry toward lead-free. The legislation ban the use of lead is only one of the driving forces. From the business point of view, the lead-free electronic product (green product) is also a market trend.

Among many developed lead-free solder alloys, SnAgCu lead-free solder alloy is considered by the electronics industry to be the best alternative to eutectic tin-lead solder (Handwerker, 2005; Nurmi, et al., 2005). The alloy has been recommended by several industry consortiums including Inter-National Electronics Manufacturing Initiative (iNEMI), EU consortium known as IDEALS (Improved Design Life and Environmentally Aware Manufacturing of Electronic Assemblies by Lead-Free Soldering), and the Japan Electronics and Information Technology Industries Association (JEITA). One of the major differences between SnPb and SnAgCu lead-free solders is that SnAgCu solders require higher reflow temperature than eutectic SnPb. The melting point of SnAg_{3.8}Cu_{0.7} is 219°C, and that of SnAg_{3.0}Cu_{0.5} is 217°C. All are higher than eutectic SnPb solder, which has a melting point of 183°C. The high melting temperature not only requires a new reflow profile, but also increases the component stability concerns accompanying with the higher temperature. Some components may not survive at that high reflow temperature.

Effective transition from SnPb soldering to the lead-free soldering requires key implementation issues to be addressed in the electronics industry. One of the critical issues is the effect of reflow profile on lead-free solder joint reliability since reflow profile would influence wetting and microstructure of the solder joint. Solder paste needs adequate reflow temperature to melt, wet, and interact with the copper pad or other board metallization and component metallization to form the solder joint. The intermetallic layers, which act as the bond, will form during the reflow and cooling process. A suitable reflow profile is essential to form a good solder joint.

Research studies show that the peak temperature (PT) and time above liquidus (TAL) during the reflow process are the most critical parameters, impacting solder joints reliability (Arra, 2002; Salam, et al., 2004). For SnAgCu reflow soldering, a commonly accepted minimum peak temperature of 230°C is necessary to achieve acceptable solder joints. The maximum temperature, on the other hand, depends on the board size, board thickness, component configuration, material thermal mass, oven capability, and etc. These factors result in different temperature delta crossing the board, which can sometimes be as high as 20 – 25°C. Moreover, larger components and thicker boards lead to a higher temperature delta across the board. In addition, greater complexities of component configuration demand longer a TAL in order to maintain uniform peak temperature across the entire printed wiring board (PWB).

A good solder joint strength mainly depends on two parts: the microstructure of bulk solder joint and the intermetallic layer. The microstructure of SnAgCu solder joints is different from that of SnPb joints due to the presence of Cu₆Sn₅ (Note that in SnPb solder joint, Cu₆Sn₅ present at the interface between SnPb solder and the Cu pad) and Ag₃Cu intermetallic compound (IMC) in the bulk solder (Salam, et al., 2004). Generally speaking, the faster cooling rate would result in finer grain size in the solder joint, which would strengthen solder joint.

The intermetallic layer thickness is another factor that would impact solder joint strength. The intermetallic layer is a critical part of a solder joint because it facilitates bonding between the solder and the substrate. But too thick an intermetallic layer has an adversely effect because it is generally the most brittle part of the solder joint. Compared to lead-based solders, SnAgCu solders require a higher reflow temperature which leads to accelerated diffusion rates. With a higher reflow temperature and a longer TAL, more substrate metallization is dissolved and more intermetallics are formed (Arra, 2002). Solder joint strength may be affected by both lack of intermetallic formation as well as excess intermetallics. Hence, an optimum combination of peak temperature and time above liquidus is important to achieve a good solder joint.

The purpose of this experiment is to study the effect of the reflow peak temperature and time above liquidus on solder joint shear force. Nine reflow profiles for SAC 305 and nine reflow profiles for SnPb have been developed with three levels of peak temperature (230°C, 240°C, and 250°C for SAC 305; and 195°C, 205°C, and 215°C for SnPb) and three levels of time above solder liquidus temperature (30 sec., 60 sec., and 90 sec.). The shear force data of four different sizes of chip resistors (1206, 0805, 0603, and 0402) are compared across the different profiles. Note that 1206 means a component with a nominal length of .12 inch (3.0 mm) and a nominal width of .06 inch (1.5 mm). The shear force of the resistors is measured at time 0 (right after assembly). The fracture interfaces are inspected by a scanning electron microscopy (SEM) in order to determine failure mode and failure surface.

Experimental Design and Procedures

A 3² factorial design with three replications was selected in the experiment. The peak temperature and time above liquidus are two input factors and each factor has three levels: peak temperature at 230°C, 240°C, and 250°C for SAC 305 and 195°C, 205°C, and 215°C for SnPb, and TAL at 30 seconds, 60 seconds, 90 seconds, for both, as shown in Table 1. Note that the peak temperatures are 12°C, 22°C, and 32°C above SnPb or SnAgCu solder liquidus temperatures. Four different sizes of pure tin plated chip resistors, 1206, 0805, 0603, and 0402 were used in this experiment. The solder paste, components and the board metallization used in the experiment are shown in Table 2.

Table 1. Experiment matrix

Peak Temperature (°C)	SAC305	230	240	250
	SnPb	195	205	215
TAL (sec.)		30	60	90

Table 2. Solder Paste, Components, and Board in the Experiment

Solder Paste	Components & metallization	Board metallization
SAC305, Type 3 powder, No-clean flux	1206, 0805, 0603, 0402 all 100% Sn finish	OSP over Cu pad
Sn63Pb37, Type 3 powder, No-clean flux	1206, 0805, 0603, 0402 all 100% Sn finish	HASL SnPb over Cu pad

The test vehicle designed is shown in Figure 1. It is a single layer board with the board thickness of 62 mils (1.57 mm) and the board size of 3.875 x 5.375 inch². The board material is FR-4.

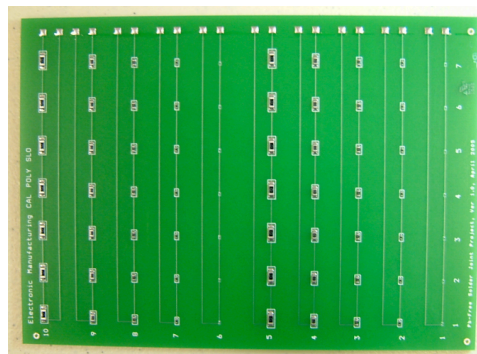

Figure1. Test Vehicle

The solder paste printing process was performed at a DEK265 series stencil printer. A 4-mil thick laser-cut electro-polished stencil was used. The printing quality was inspected using a microscope. The pick and place process was performed with a Siemens machine. A Heller 1500 convection oven with 5 heating zones and one cooling zone was used for solder reflow. The 18 reflow profiles were developed using three thermal couples attached to the test vehicle where covered the diagonal corners of the board and the center. A linear ramp-up method was used for developing reflow profiles. Details information

on linear ramp-up method please refers to (Bentzen, 2000; TKB-4U). Figure 2 shows a sample lead-free reflow profile.

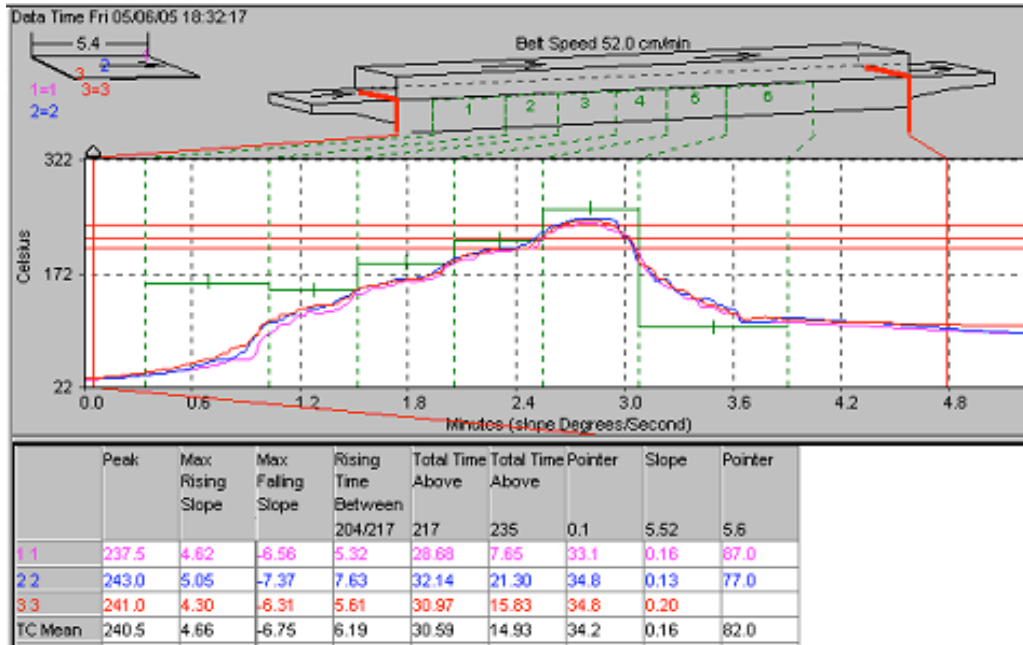

Figure 2. A sample lead-free reflow profile

Since it is a 3^2 factorial design with three replications, 27 boards were assembled using SnPb paste and 27 boards were assembled using SAC305 paste. The assembly was conducted over two days, the SnPb boards were assembled in one day and SAC305 boards were assembled the next day. The assembly sequence in each day was randomized to minimize the nuisance factors such as room temperature, humidity, and other conditions. To be consistent, the process parameters for the stencil printing and pick & place were the same. The only variable is the reflow profile. When moving from one profile to another, the oven settings were changed and allowed to get to temperature (e.g. waiting for green light), and then allowed to stabilize for 5 minutes.

All boards were visually inspected after stencil printing, after pick and place, and after reflow. The only difference between SnPb solder joints and SAC305 solder joints after reflow is that SnPb joints look shiny and SAC305 joints look dull. Figure 3 shows sample microscopy images after printing, after component being placed, and after reflow.

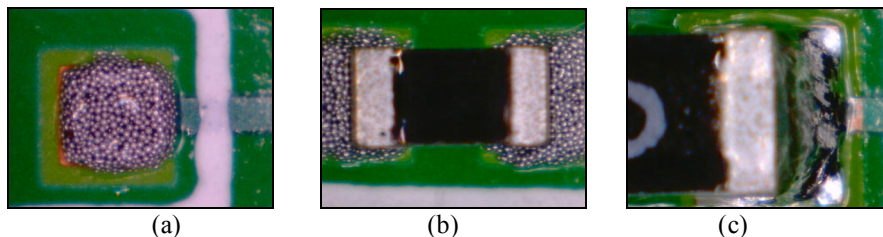

Figure 3. Microscope images (a) after stencil printing (b) after component being placed (c) after reflow

Shear test was performed using a Dage-series 4000 shear tester. Table 3 shows the parameters of the shear test machine. Note that the shear force depends on shear speed (Newman, 2005). Each board was cut into two identical pieces. The first half of the board stands for the initial time zero (right after assembly) and the other half was used for air-to-air thermal shock testing. For the first half samples, six components for each type (e.g. 0603, 1206, etc.) on each board were sheared with one component left for SEM analysis. Therefore, 1292 data (6 components x 3 boards x 4 components sizes x 18 reflow profiles) were collected. Note that the sample size for each component type and reflow profile is 18 (6 components per board x 3 boards). The peak shear force and failure modes were recorded.

It should be noted that only two failure modes were observed during the shear testing. They are fracture at the solder joint and component failure. For most of the samples the fracture mode was at the solder joint interface. In the data analysis described in the next section, the shear force of samples where the component failed were not considered. Only the shear force data with solder joint fracture were analyzed.

Table 3. Shear tester parameters

Parameters	Settings
Range	20 Kg
Test Speed	8.00 mil/sec
Test Load	0.5 kg
Land Speed	19 mil/sec
Shear Height	5.00 mil
Over Travel	10.00 mil

Statistical Data Analysis

The solder joint shear force data were analyzed using analysis of variance (ANOVA). First, the validity of three assumptions (normally, independently, and constant variance of the residues) of ANOVA was checked. As shown in Figures 4 and 5, the residual vs. predicted shear force plots show that the residual variances are not constant. In order to make the ANOVA analysis valid, a transformation is necessary. We found the square root transformation is appropriate in this case.

Residual Plot for Shear Force of SnPb Solder Joints

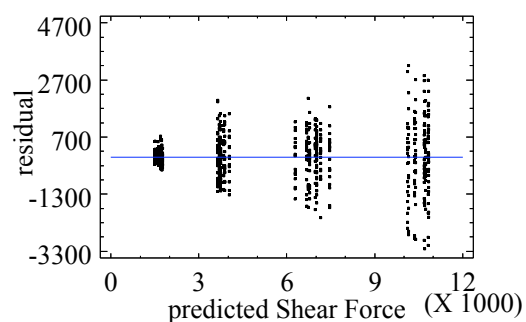

Figure 4. Plot of residuals versus predicted shear force of SnPb joints

Residual Plot for Shear Force of SAC305 Solder Joint

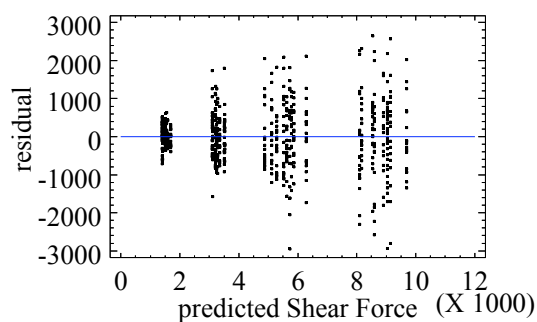

Figure 5. Plot of residuals versus predicted shear force of SAC305 joints

The ANOVA table for the square root of the SAC305 shear force (shear force after transformation) is shown in Table 4. The P-value of less than 0.05 indicates that the factor has statistically significant effect at the 95% confidence level. Table 4 shows that the component size, reflow peak temperature and TAL have statistically significant effect on the shear force. It is intuitive that component size has significant effect on the solder joint shear force since big components have larger contact areas. Figure 6 shows that the peak temperature of 250C results in the highest shear force while there is no significant difference on shear force between the peak temperature of 230C and 240C. Figure 7 shows TAL of 30 seconds results in the highest shear force while there is no significant difference on shear force between the TAL of 60 seconds and 90 seconds.

The ANOVA table for the square root of the SnPb shear force (shear force after transformation) is shown in Table 5. It shows that only the component size and the peak temperature have statistically significant effect on the shear force. TAL does not have statistically significant effect on the SnPb solder joint shear force. Figure 8 shows that the peak temperature of 215C results in a slightly higher shear force while there is no significant difference on shear force between the peak temperature of 195C and 205C.

Table 4. ANOVA for the Square Root of the SAC305 Shear Force

Source	Sum of Squares	Df	Mean Square	F-Ratio	P-Value
Main Effects					
A: Component Size	267930.0	3	89310.1	3381.98	0.0000
B: Peak Temp	947.76	2	473.88	17.94	0.0000
C: TAL	895.531	2	447.766	16.96	0.0000
Interactions					
AB	241.806	6	40.301	1.53	0.1670
AC	428.161	6	71.3602	2.70	0.0134
BC	160.009	4	40.0022	1.51	0.1962
RESIDUAL	16478.4	624	26.4077		
TOTAL (CORRECTED)	287082.0	647			

Means and 95.0 Percent LSD Intervals of SAC305 Solder Joints

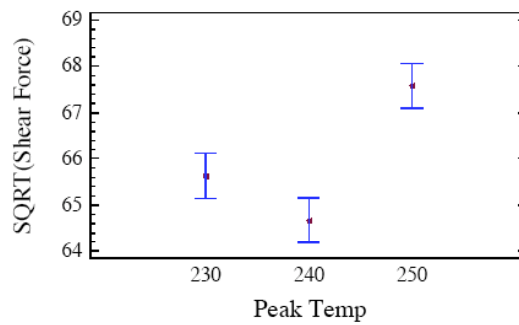

Figure 6. Effect of Peak Temperature on SAC305 Solder Joint Shear Force

Means and 95.0 Percent LSD Intervals of SAC305 Solder Joints

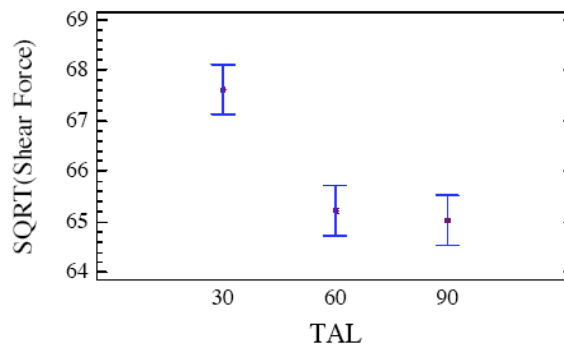

Figure 7. Effect of TAL on SAC305 Solder Joint Shear Force

Table 5. ANOVA for the Square Root of the SnPb Shear Force

Source	Sum of Squares	Df	Mean Square	F-Ratio	P-Value
Main Effects					
A: Component Size	345244.0	3	115081.0	4011.01	0.0000
B: Peak Temp	189.029	2	94.5145	3.29	0.0377
C: TAL	51.9084	2	25.9542	0.90	0.4052
Interactions					
AB	349.653	6	58.2755	2.03	0.0596
AC	358.652	6	59.7754	2.08	0.0533
BC	135.373	4	33.8432	1.18	0.3186
RESIDUAL	17903.4	624	28.6914		
TOTAL (CORRECTED)	364232.0	647			

Means and 95.0 Percent LSD Intervals of SnPb Solder Joints

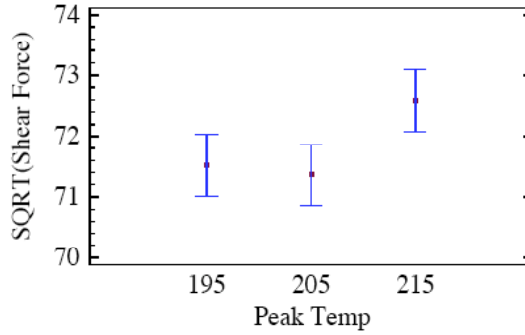

Figure 8. Effect of Peak Temperature on SnPb Solder Joint Shear Force

In this study, ANOVA for each component size was conducted as well. The effects of the peak temperature and the TAL are summarized in Table 6. The results are confusing because the effect of the peak temperature and the TAL are different for different component sizes. To understand the experimental results, failure analysis using Scanning Electron Microscopy (SEM) with energy dispersive spectroscopy (EDS) was performed and our findings will be presented in the next section.

Table 7 summarizes the mean shear force for different component sizes. It shows that the shear force of SnPb solder joints is higher than that of SAC305 solder joints for the same component size. The shear force equals to the shear strength of the joint times the joint contact area (or the solder wetting area). The published shear strength of Sn37Pb solder alloy is 6060 psi or 45.5MPa in Table 1.14 of the NIST solder properties database (Siewert, et al., 2002) and the shear strength of Sn3.8Ag0.7Cu alloy is 63.8 MPa in Table 1.17 of the NIST solder properties database (Siewert, et al., 2002). It is reasonable to assume that the shear strength of Sn3.8Ag0.7Cu is similar to that of Sn3.0Ag0.5Cu. Since the shear strength of SnPb is lower than that of SnAgCu, the only possible reason for the higher shear force of SnPb than that of SnAgCu is that the joint contact area of SnPb is larger than that of SnAgCu if the fracture is in the bulk solder joint; this correlates with the known wetting difference between SnAgCu and SnPb solders. The fracture area of solder joints will be examined using an optical microscopy and the results will be presented in the next section. In the published literature, conflicting results of the SnPb solder joint shear force and SnAgCu solder joint shear force were reported. For example, Oliver, et al. (2000) reported that the shear force of Sn37Pb was unexpectedly higher than that of lead-free solder joints before thermal aging. Sampathkumar, et al. (2005) reported that the shear force of SnAgCu solder joints is higher than that of SnPb solder joints.

Table 6. Summary of ANOVA Results for Each Component Size

		SAC305	SnPb
1206	Peak Temperature	Significant	Not significant (P value = 0.6)
	TAL	Significant	Not significant (P value = 0.1)
0805	Peak Temperature	Significant	Significant
	TAL	Significant	Significant
0603	Peak Temperature	Not significant (P value = 0.07)	Not significant (P value = 0.27)
	TAL	Not significant (P value = 0.2)	Not significant (P value = 0.66)
0402	Peak Temperature	Not significant (P value = 0.1)	Not significant (P value = 0.46)
	TAL	Not significant (P value = 0.06)	Not significant (P value = 0.55)

* Significance at 95% confidence level

Table 7. Comparison of Shear Force Between SnPb Solder Joints and SAC305 Solder Joints

Component Size	Average Shear Force of 324 SAC305 Solder Joints (grams)	Average Shear Force of 324 SnPb Solder Joint (grams)
0402	1514	1677
0603	3283	3770
0805	5570	6900
1206	8806	10536

Optical Inspection and SEM Analysis

To explain why the shear force of SnPb solder joints is higher than that of SAC305 solder joint, an optical microscope is used to examine the fracture area of SnPb solder joints and SAC305 solder joints. Figures 9 and 10 show typical fracture areas of SAC305 solder joints and SnPb solder joints. Note that the TAL and the temperature difference between the peak

temperature and the liquidus temperature are same for both SnPb and SAC305 solder joints in Figures 9 and 10. Figures 9 and 10 clearly show that the fracture areas of SnPb joints are larger than that of SAC305 joints. Here the joint contact area in fillet (side) is not considered.

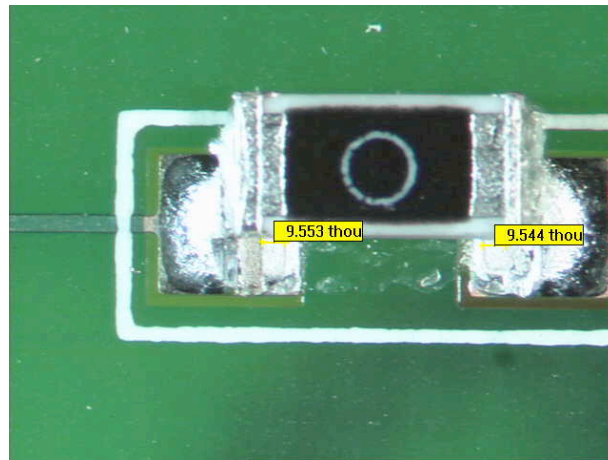

Figure 9. Fracture Area of SAC305 Joint Reflowed at 230C for 30 sec.

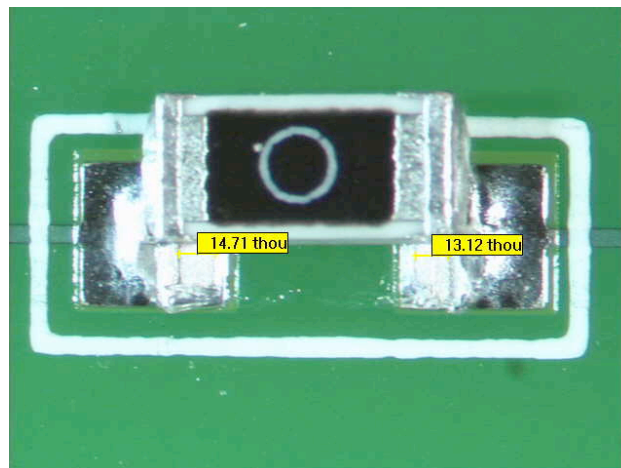

Figure 10. Fracture Area of SnPb Joint Reflowed at 195C for 30 sec.

To understand why the effects of the peak temp and the TAL are not consistent for different component sizes and for SnPb and SAC305 solder joints, SEM analysis was conducted. Figures 11 and 12 show the SEM pictures of SnPb joint fracture area and SAC305 joint fracture area. It is interesting to note that Ag was detected in the fracture area.

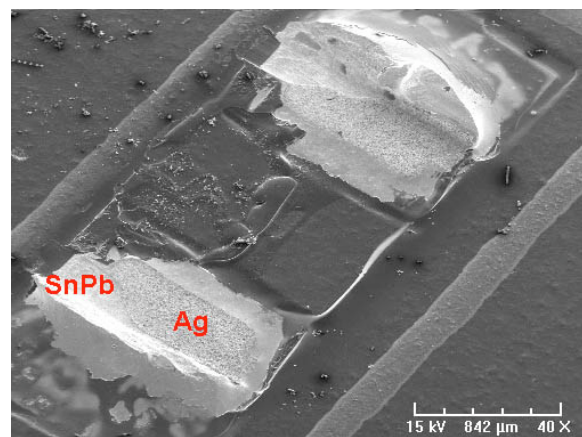

Figure 11. Fracture Area of SnPb Joint Reflowed at 215C for 90 sec.

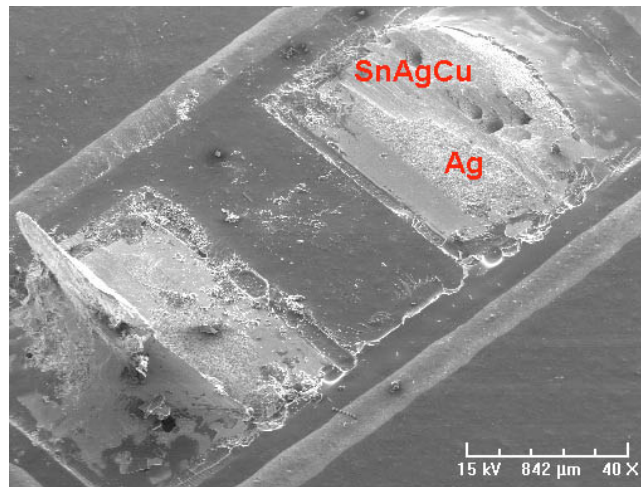

Figure 12. Fracture Area of SAC305 Joint Reflowed at 250C for 90 sec.

A typical termination structure of lead-free chip resistor is shown in Figure 13. Since Ag presents in the fracture area, it means that the fracture happens partially in the termination metallization and partially in the bulk solder joints. Since the shear area in termination metallization varies from different components and component sizes, this may be the reason why the effects of the peak temperature and the TAL are not consistent for different component sizes and for the SnPb and SAC305 joints.

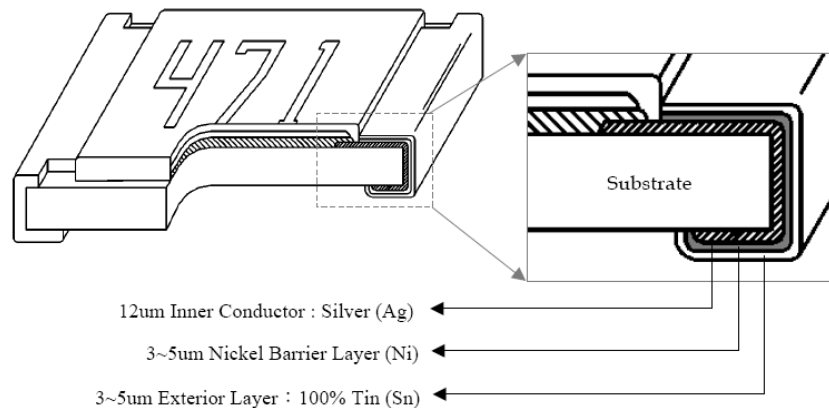

Figure 13. Typical Termination Structure of Lead Free Chip Resistor (source: TopLine)

The cross-section of both the SnPb solder joint and the SAC305 solder joint at the highest peak temperature setting (215C for SnPb solder and 250C for SAC305 solder) and the longer TAL (90 seconds) are shown in Figures 14 and 15.

The other half of the boards (Phase 2) is undergoing the air-to-air thermal shock cycling. The data and analysis will be published later.

Conclusions

The following conclusion can be drawn from this study:

- 1) The effects of the peak temp and the TAL are not consistent for different component sizes and for SnPb and SAC305 solder joints.
- 2) The fracture areas are observed partially in the termination metallization (Ag layer) and partially in the bulk solder joints.
- 3) The shear force of SnPb solder joints is higher than that of SAC305 solder joint because the wetting of SnPb is better than that of SnAgCu.

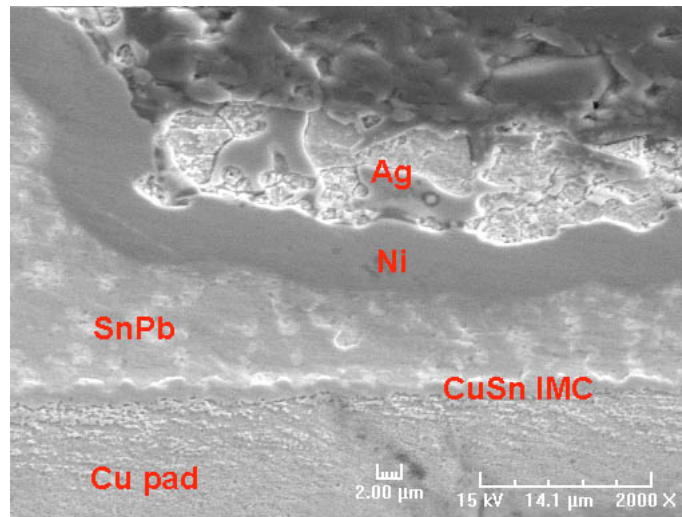

Figure 14. Cross-section View of SnPb Solder Joint Reflowed at 215C for 90 sec.

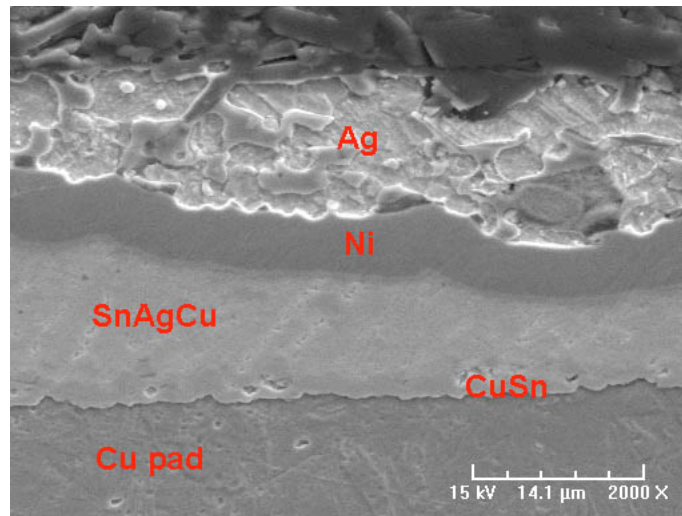

Figure 15. Cross-section View of SAC305 Solder Joint Reflowed at 250C for 90 sec.

Acknowledgement

This work was partially sponsored by the Department of the Navy, Office of Naval Research, under Award # N00014-05-1-0855. The authors would like to thank Henkel Technologies for providing a stencil, solder paste, shear testing, and SEM sample preparation. The authors also want to thank Charlson Bernal and Roger Jay for SEM analysis, Jasbir Bath, Dennis Willie, Kim Hyland of Solectron Corp. for technical support. Special thanks to Flextronics International, DEK, Siemens, and Heller Industries for sponsoring the surface mount assembly line at Cal Poly, where the boards were assembled.

References

- Arra, M.; Shangguan, D.; Ristolainen, E.; and Lepisto, T., "Effect of Reflow Profile on Wetting and Intermetallic Formation Between Sn/Ag/Cu Solder Components and Printed Circuit Boards," *Soldering and Surface Mount Technology*, Vol. 14 No. 2, pp.18-25, 2002.
- Bentzen, B., "Reflow Soldering," *SMT in FOCUS*, Oct. 2000, available at www.smtinfofocus.com
- Handwerker, C. (2005), "Transitioning to Lead-free Assemblies," *Printed Circuit Design and Manufacture*, March 2005, pp. 17-23.
- Newman, K., "BGA Brittle Fracture Alternative Solder Joint Integrity Test Methods," Proceedings of IEEE/ECTC the 55th Electronic Components and Technology Conference, May 31-June 3, 2005, Lake Buena Vista, FL.
- Nurmi, S. T.; Sundelin, J. J.; Ristolainen, E. O.; and Lepisto, T., (2005), "The effect of PCB surface finish on lead-free solder joints," *Soldering & Surface Mount Technology*, Vol. 17, No. 1, pp. 13-23.

Oliver, J.R.; Liu, J.; and Lai, Z., "Effect of Thermal Aging on the Shear Strength of Lead-free Solder Joints," Proceedings of the 2000 International Symposium on Advanced Packaging Materials, pp. 152-157.

Salam, B.; Virseda, C.; Da, H.; Ekere, N.N.; and Durairaj, R., "Reflow Profile Study of the Sn-Ag-Cu Solder," *Soldering and Surface Mount Technology*, Vol. 16 No. 1, pp.27-34, 2004.

Sampathkumar, M.; Rajesnayagham, S.; Ramkumar, S.M.; and Anson, S.J., "Investigation of the Performance of SAC and SACBi Lead-free Solder Alloys with OSP and Immersion Silver PCB Finish," Proceedings of SMTA International 2005, Chicago, IL, USA, Sept. 25-29, 2005, pp. 568-575.

Siewert, T.; Liu, S.; Smith, D. R.; and Madeni, J. C., (2002), "Database for Solder Properties with Emphasis on New Lead-free Solders," NIST & Colorado School of Mines, Release 4.0, Feb. 2002, available at

[http://www.boulder.nist.gov/div853/lead free/solders.html](http://www.boulder.nist.gov/div853/lead_free/solders.html)

TKB-4U, "Minimizing defects on board assemblies by reflow profile adjustments," Europe, Available at

<http://www.tkb-4u.com/articles/soldering/reflprofadjust/reflprofadjust.php>